



# The Royal Scottish Country Dance Society

## Stockholm Branch

### Dansprogram 29 april 2024

Tack för en trevlig danskväll den 22/4 med nya informationen Rondel – de gjorde ni bra! Vi fick också oväntat besök av Jonathan Lewis från London Branch, så kul då vi också avslutade med Pub-besök efter dansen för mer kontakt med Jonathan och varandra under pågående termin.

På måndag den 29/4 åker Anders och jag till Spanien ett par veckor (åter 16/5) och ni kommer att repetera Robertson Rant och Three Sisters, samt ett par av de mer avancerade danserna vi kommer att ha vid vårterminens avslutning den 27/5 då vi dansar tillsammans med nybörjarna.

#### Uppvärmning

#### THE ROBERTSON RANT (S80) Sq. Set      Mrs Douglas Winchester RSCDS Bk 39

- 1- 8      All circle 8H round & back
- 9-16      All Ladies dance RH across 1/2 way & turn opposite Man LH, all Ladies dance 1/2 RH across & turn partner LH.
- 17-24      1s+3s **dance reel of 4** (Ladies start by passing LSh as Men set)
- 25-32      All set (HS) to corners, turn 2H twice.
- 33-40      2s+4s dance reel of 4 (Ladies start by passing LSh as Men set)
- 41-48      All set (HS) to corners, turn 2H twice.
- 49-56      All Ladies circle left to face partners (Ladies BtoB), set to & turn partners 2H
- 57-64      All Men circle right to face partners (Men BtoB), set to & turn partners 2H
- 65-72      All dance **Grand Chain** (Starfish formation)
- 73-80      All take allemande hold & dance anticlockwise once round set, bringing Ladies into centre for bow/curtsey.

HS = Highland Schottische Step

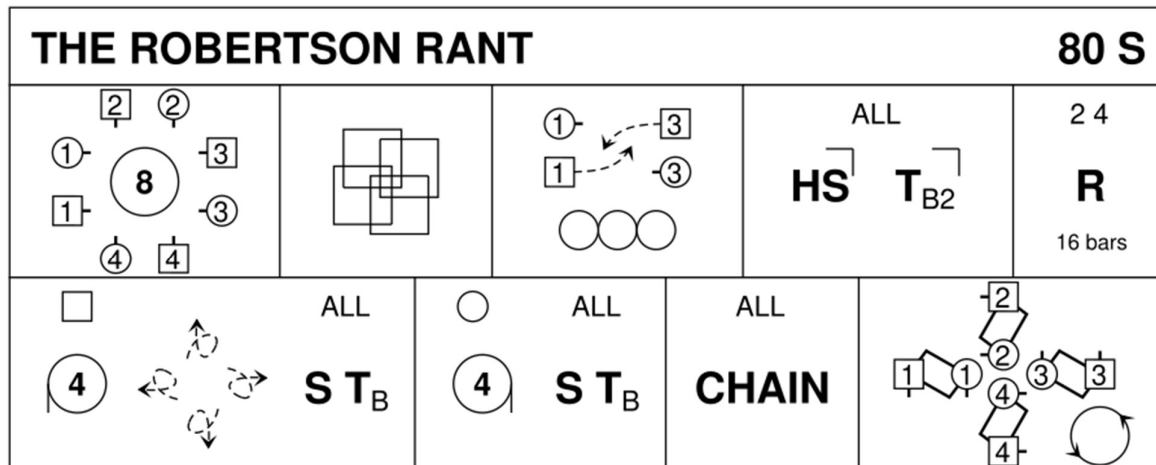

Mrs Douglas Winchester, 1949, RSCDS Book 39.8

4C/4C square set.



# The Royal Scottish Country Dance Society

## Stockholm Branch

### PELORUS JACK (J8x32) 3C (4C set)

**Barry Skelton RSCDS Bk 41**

- 1- 8        1s cross RH & cast 1 place (2s step up 3-4), 1s dance RH across with 3s. 1s end with Man facing his 1st corner with his partner behind him.
- 9-16      1s dance Alternating Tandem 1/2 reel of 3 with 1st corners to face Man's 2nd corner, 1s dance Alternating Tandem 1/2 reel of 3 with 2nd corners.
- 17-24    1s dance Alternating Tandem 1/2 reels of 3 with Ladies' 1st corner (pstrn), 1s dance Alternating Tandem 1/2 reel with Ladies' 2nd corner (pstrn)
- 25-32    1M followed by partner dance into LH across with 2s, 1s retain LH & 1/2 turn to own sides & 2s+1s+3s set.

<b>PELORUS JACK</b>				<b>8x32 J</b>	
1x 3 <b>X<sub>R</sub></b> 1 <b>RA</b>					2 1x   1x 2 1 3 <b>LA</b>   <b>T<sub>L</sub><sup>1</sup>/<sub>2</sub></b>   <b>S</b>
	Change lead at end of reel		Change lead at end of reel		

Barry Skelton, 1993, Dolphin Book, RSCDS Book 41.1, RSCDS Thirty Popular Dances Vol 2

3C/4C longwise set.

### THE THREE SISTERS (S8x32) 3C (4C set)

**John Drewry**

- 1- 8        1L+2L+3L Adv+Ret & set; **while** Men set & Adv+Ret; 1s+2s+3s cross RH to opposite sides
- 9-16      All set; **petronella** turn to centre; turn partners 2H & petronella turn to pl (1L+2M end face out)
- 17-24    1s+2s dance **reel of 4 across** dance (1M+2L pass LSh to start & 1L+2M pass partners RSh)
- 25-32    1s+2s dance the **Rondel**.

<b>THE THREE SISTERS</b>		<b>Drewry</b>	<b>** S32</b>
{ □ ↑ ↓ S 123 ○ S ↑ ↓ X <sub>R</sub>	123 ——— S ⬠ T <sub>B</sub> ⬠		1 2 <b>RONDEL</b>



# The Royal Scottish Country Dance Society

## Stockholm Branch

- JENNIFER'S JIG (J8x32) 3C (4C set)      John Drewry Silver City Bk & RSCDS Bk 53**
- 1- 8      1s+2s+3s set cross RH, set & cross back RH
  - 9-16     1s+2s dance double Fig of 8 (1s cross down to start)
  - 17-24    1s dance **Inveran reels** with 2s+3s
  - 25-32    1s followed by 2s lead down 3 steps, turn RH (3 bars) & 2s lead up followed by 1s to new places.

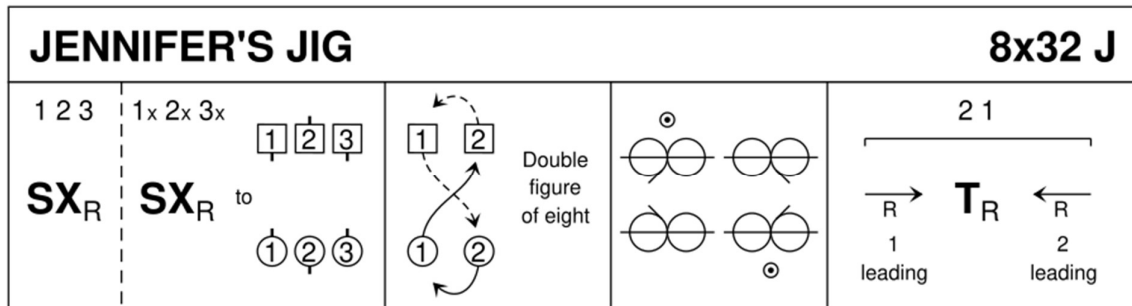

John Drewry, 1968, RSCDS Book 53, Silver City

3C/4C longwise set.

- ANNA HOLDEN'S STRATHSPEY (S8x32) 2C (4C set)      John Drewry RSCDS Bk 42**
- 1- 8      1s+2s dance RH across, 1s cross down to 2nd pl as 2s cast up then 1M+2L turn LH as 1L+2M turn RH into a line across (1s between 2s) facing down
  - 9-16     1s+2s dance down in line, 1s turn & face up as 2s turn in behind, dance up, 1s casting to 2nd place opposite sides as 2s dance to 1st place own sides.
  - 17-24    2M+1L also 2L+1M set & Petronella turn-in-tandem into middle, set & Petronella turn-in-tandem to sides.
  - 25-32    1s+2s set, circle 4H round 1/2 way; 1s turn 2H 1.1/2 times to 2nd place own side.

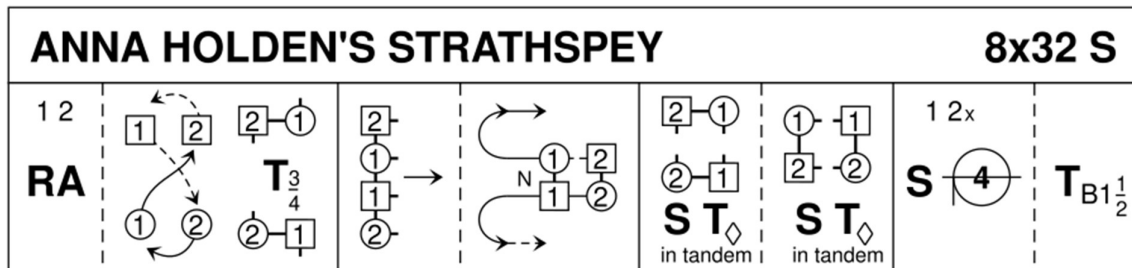

John Drewry, 1991, RSCDS Book 42.2

2C/4C longwise set.



# The Royal Scottish Country Dance Society

## Stockholm Branch

**THE SOMERSET CHILDREN'S REEL (R8x32) 3C (4C set)**

**RSCDS Bk 51**

- 1- 8            1s+2s dance RH across, LH back
- 9-16          1s lead down (2 steps), retain RH & set to each other, lead up to top & cast (2s step up 15-16)
- 17-24        1s+3s dance Double Fig 8 (1s cross down, 3s dance up to start)
- 25-32        2s+1s+3s circle 6H round & back

<b>THE SOMERSET CHILDREN'S REEL</b>				<b>8x32 R</b>	
1 2	1 2				
<b>RA</b>	<b>LA</b>	→ R	<b>S</b>	← R	↻ <b>1</b>
				◇ 1    ◇ 3	2 1 3
				DOUBLE FIGURE EIGHT	⊙ <b>6</b>
				①    ③	

Elizabeth Beckinsale, 2015, RSCDS Book 51

3C/4C longwise set.