



The Royal Scottish Country Dance Society

Stockholm Branch

Dansprogram 22 april 2024

Hej

Denna gång kommer vi bland annat att lägga fokus på Rondel så vi bifogar en beskrivning av den separat från danserna. Det är också viktigt att så många som möjligt kommer eftersom Lena, Tanja och Erika kommer att ha en aktivitet med nybörjarna och inte kan delta i Intermediate/Advanced.

Uppvärmning

THE ROBERTSON RANT (S80) Sq.Set Mrs Douglas Winchester RSCDS Bk 39

- 1- 8 All circle 8H round & back
- 9-16 All Ladies dance RH across 1/2 way & turn opposite Man LH, all Ladies dance 1/2 RH across & turn partner LH.
- 17-24 1s+3s **dance reel of 4** (Ladies start by passing LSh as Men set)
- 25-32 All set (HS) to corners, turn 2H twice.
- 33-40 2s+4s dance reel of 4 (Ladies start by passing LSh as Men set)
- 41-48 All set (HS) to corners, turn 2H twice.
- 49-56 All Ladies circle left to face partners (Ladies BtoB), set to & turn partners 2H
- 57-64 All Men circle right to face partners (Men BtoB), set to & turn partners 2H
- 65-72 All dance **Grand Chain** (Starfish formation)
- 73-80 All take allemande hold & dance anticlockwise once round set, bringing Ladies into centre for bow/curtsey.

HS = Highland Schottische Step

THE ROBERTSON RANT				80 S
			ALL HS T_{B2}	2 4 R 16 bars
	ALL S T_B		ALL S T_B	CHAIN

Mrs Douglas Winchester, 1949, RSCDS Book 39.8

4C/4C square set.







The Royal Scottish Country Dance Society

Stockholm Branch

J. B. MILNE (R8x32) 3C (4C set)

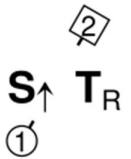
Hugh Foss Angus Fitchett Album

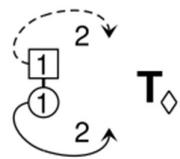
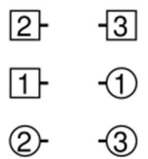
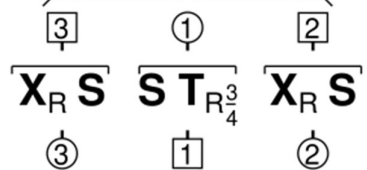
- 1- 8 1M+2L set advancing & turn RH, 1L+2M set advancing & turn RH
- 9-16 1s set advancing to each other & turn 2H, cast to 2nd place & **Petronella** turn to Lady between 2s & Man between 3s.
- 17-24 1s set & 3/4 turn RH **while** 2s+3s change places RH on sides & set, 1s repeat but 2s & 3s cross RH & set.
- 25-32 1s set & change places RH **while** 2s+3s change places RH on sides & set, 1s cast round corner to 2nd pl own sides **as** 2s+3s cross RH & all set.

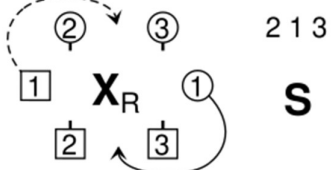
J. B. MILNE				8x32 R
				
				

Hugh Foss, 1954, Angus Fitchett S D Album, RSCDS Thirty Popular Dances Vol 2

3C/4C longwise set.

THE THREE SISTERS (S8x32) 3C (4C set)

John Drewry

- 1- 8 1L+2L+3L Adv+Ret & set; **while** Men set & Adv+Ret; 1s+2s+3s cross RH to opposite sides
- 9-16 All set; **petronella** turn to centre; turn partners 2H & petronella turn to pl (1L+2M end face out)
- 17-24 1s+2s dance **reel of 4 across** dance (1M+2L pass LSh to start & 1L+2M pass partners RSh)
- 25-32 1s+2s dance the **Rondel**.

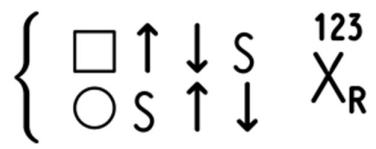
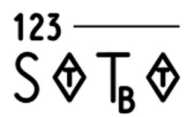
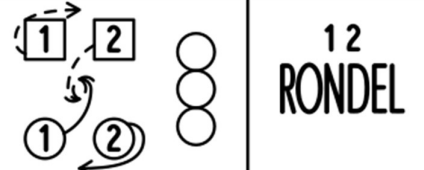
THE THREE SISTERS	Drewry	** S32
		



The Royal Scottish Country Dance Society

Stockholm Branch

- THE THREE SHIRES (R8x32) 3C (4C set) Ann Dix Three Hands Across**
- 1- 8 1s dance down the middle, set to partner & face up, 1M dances LH across with 2M+3M while 1L dances RH across with 2L+3L
- 9-16 1s dance up & cast 1 place to end LSh to LSh facing opposite sides, 1L dances RH across with 2s as 1M dances RH across with 3s.
- 17-24 1s dance 'Hello-Goodbye' setting ending with 3/4 RH turn to 2nd place own side.
- 25-32 2s+1s+3s circle 6H round and back

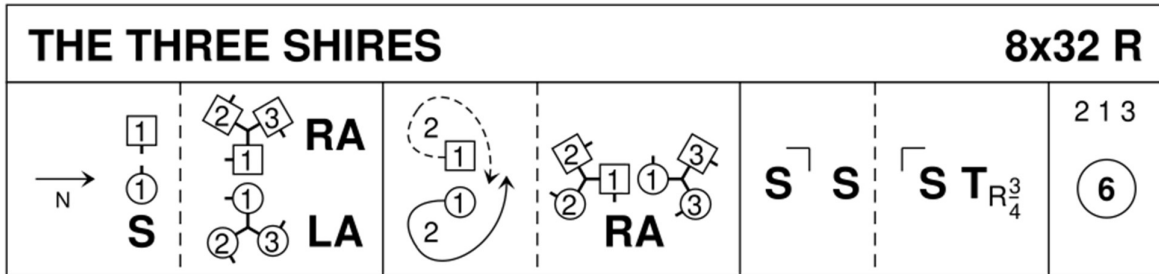

Ann Dix, Three Hands Across

3C/4C longwise set.

- JENNIFER'S JIG (J8x32) 3C (4C set) John Drewry Silver City Bk & RSCDS Bk 53**
- 1- 8 1s+2s+3s set cross RH, set & cross back RH
- 9-16 1s+2s dance double Fig of 8 (1s cross down to start)
- 17-24 1s dance **Inveran reels** with 2s+3s
- 25-32 1s followed by 2s lead down 3 steps, turn RH (3 bars) & 2s lead up followed by 1s to new places.

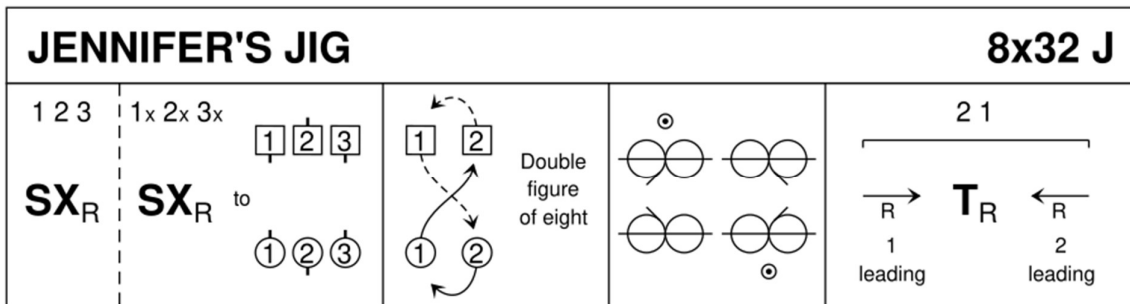

John Drewry, 1968, RSCDS Book 53, Silver City

3C/4C longwise set.



The Royal Scottish Country Dance Society

Stockholm Branch

THE RONDEL

This formation is a method of progression usually in strathspey time. It is danced by two couples. It begins in the middle of the set, 1st couple facing down and 2nd couple facing up, nearer hands joined.

Steps: 8 travelling steps

No. of bars: 8 Bars

- 1 1st couple dance down through the arch made by 2nd couple who dance up.
- 2 Each man crosses his partner in front of him and all dance in a curve towards the opposite side.
- 3 Both women dance to meet each other and join nearer hands on the men's side as the men do the same on the women's side. They face their partner across the set.
- 4 All cross to their own side. The women, retaining nearer hands, dance through the arch made by the men.
- 5 2nd couple cross 1st couple in front of them. 1st couple dance up and 2nd couple dance down.
- 6 Both couples dance in a curve to meet partners, 1st couple facing down and 2nd couple facing up, with nearer hands joined.
- 7 1st couple dance down through the arch made by 2nd couple who dance up.
- 8 Both couples dance out to own sides, having changed places.

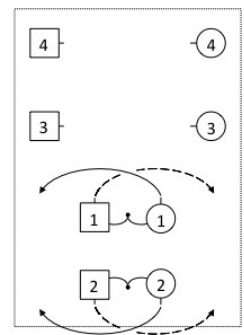
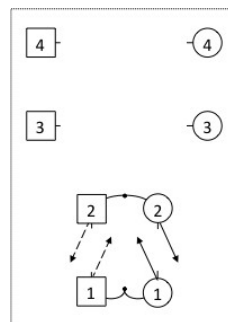
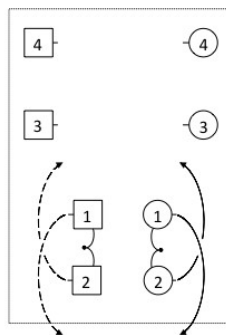
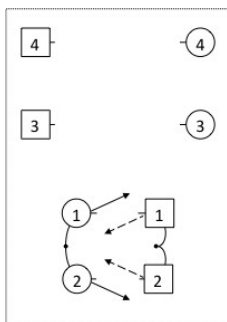

Top Bar 1

Top Bar 2