



# The Royal Scottish Country Dance Society

## Stockholm Branch

### Dansprogram 23 februari 2026

Hej alla dansare

Vi fortsätter med att gå igenom lite mer avancerade figurer genom dels nya och repetition av dem vi gjort tidigare. Denna gång blir det först The Knot och Corners pass and turn och sedan repetition av Links with St. Petersburg och Hello Goodbye Setting. Sist gör vi ett nytt försök att dansa Hoopers Jig som vi fick stryka på grund av tidsbrist tidigare.

Susanne och Tanja

#### TRIPLE HAPPINESS (S3x32) 3C

Yoshiki Oyama RSCDS Bk 52

- 1- 8            1s Adv+Ret (1 step each) taking RH briefly, 1s 1/2 turn LH, cross down between 2s & cast up to place
- 9-16           1s+2s dance the Knot. 1s end facing 1st corners
- 17-24          1s dance Corners Pass+Turn with 1st corners, pass RSh, Repeat with 2nd corners & 1s pass RSh into 2nd place own sides (corners turn 2H in centre)
- 25-32          All chase clockwise 1/2 round to opp sides, all 1/2 turn 2H, pull back RSh & dance out to own sides 3 1 2

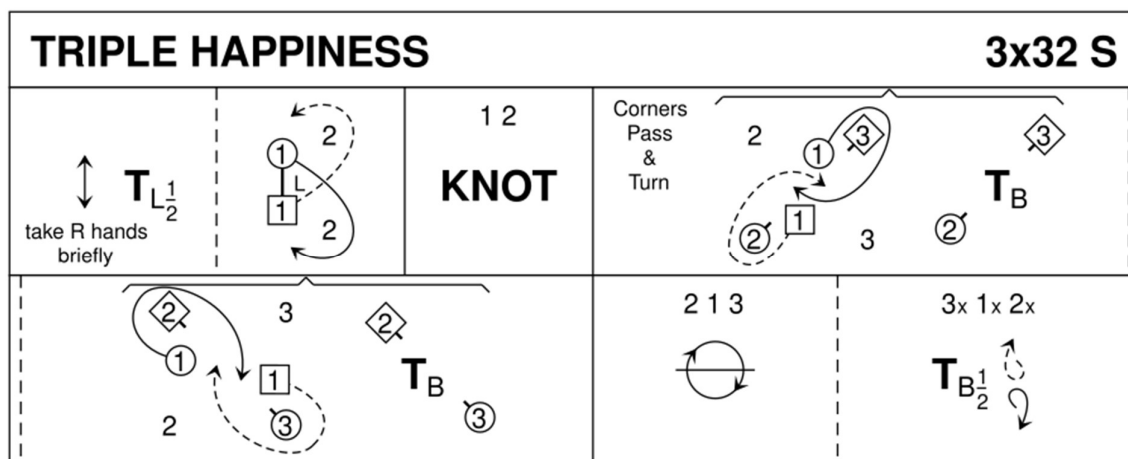

Yoshiki Oyama, 2016, RSCDS Book 52.10

3C/3C longwise set.



# The Royal Scottish Country Dance Society

## Stockholm Branch

### LINKS WITH ST PETERSBURG (J8x32) 3C (4C set) Malcolm Brown RSCDS Bk 46

- 1- 8            1s & 2s Set+Link ending 2s facing 1s NHJ, 2s & 1s Set+Link with partners to opposite sides. (2)(1)3
- 9-16          1s followed by 2s dance down for 3 bars & change places with Lady dancing under Mans arm, 2s+1s dance up to 1st & 2nd places
- 17-24        2M+1M turn LH as 2L+1L turn RH, 1M+3M turn RH as 1L+3L turn LH & 1s end facing 1st corners
- 25-32        1s dance 'Hello-Goodbye' setting & petronella turn to 2nd place own sides

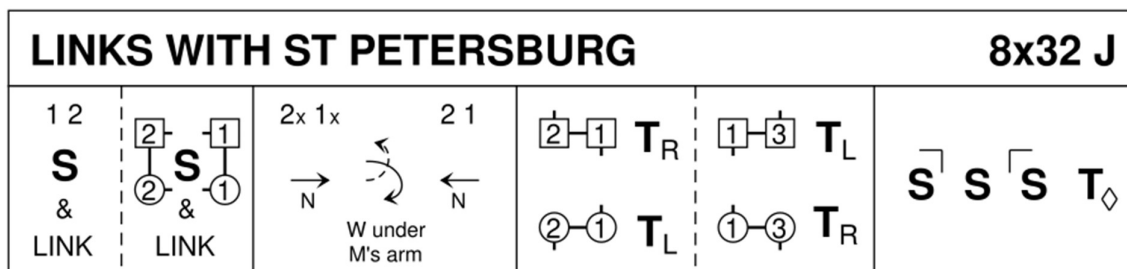

Malcolm Brown, 2009, RSCDS Book 46.10

3C/4C longwise set.

### HOOPER'S JIG (J8x32) 3C (4C set)

MMM 2

- 1- 8            All clap & 1s cross passing RSh, cast to 2nd place & dance RH across with 3s
- 9-16          All clap & 1s cross passing RSh, cast to 1st place & dance LH across with 2s
- 17-24        1M+3L change places RH & 1L+3M change places RH (as 1M+3L loop round), 1M+3L change places RH (as 1L+3M loop round) & 1L+3M cross LH 1L ending in 2nd place (as 1M casts to 2nd pl), 2s step up on bars 23 - 24
- 25-32        2s+1s dance R&L. 2 1 3

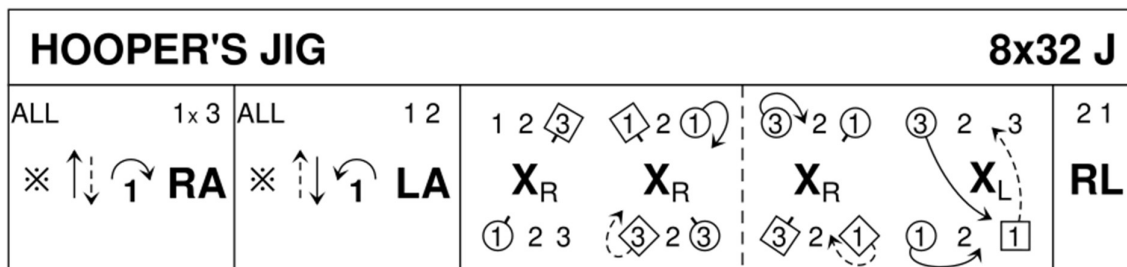

RSCDS MMM (34), RSCDS Thirty Popular Dances Vol 2

3C/4C longwise set.