



The Royal Scottish Country Dance Society

Stockholm Branch

Dansprogram 2 februari 2026

Hej alla dansare

Den här gången repeterar vi danser med formationerna Corner-pass-and-turn, Set and Link samt Hello-Goodbye. Vi kommer också att träna en ny dans med formationen Bourelle-for-two-Couples. Se gärna filmerna på Facebook sidan.

Susanne och Tanja

TRIP TO TIMBER RIDGE (R8x32) 3C (4C set)

RSCDS Bk 52

- 1- 8 1s turn RH, cast (2s step up) then 1L+2s & 1M+3s dance RH across. 1s end facing 1st corners
- 9-16 1s dance Corner Pass+Turn with 1st corners, pass RSh & repeat with 2nd corners. 1s pull back RSh to end BtoB in centre facing opposite sides
- 17-24 2s+1s+3s dance Double Triangles. Bars 23-24 1s petronella turn to 2nd place own sides
- 25-32 2s+1s+3s circle 6H round and back

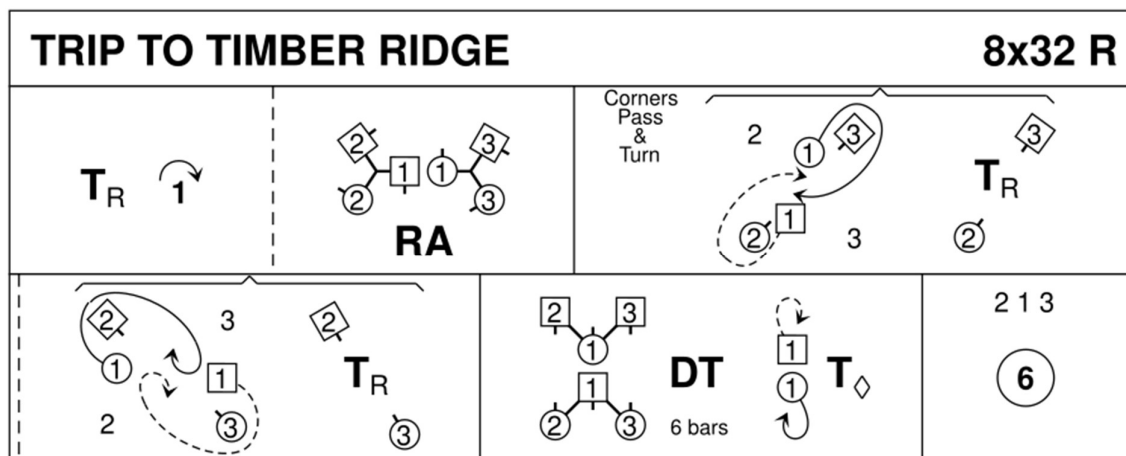

Linda Henderson, 2010, RSCDS Book 52.12

3C/4C longwise set.



The Royal Scottish Country Dance Society

Stockholm Branch

THE NORTHERN LIGHTS (S3x32) 3C set Charles Doble TAC Silver Anniv Dances

- 1- 4 1s+2s dance the Bourrel -1M+2L set advancing & turn 2H to end BtoB Lady facing up & Man down **while** their partners chase anticlockwise to face partner
- 5- 8 1s+2s set & 3/4 turn 2H to own sides 2 1
- 9-16 1s+3s repeat bars 1-8 & 2s+3s+1s end in middle for...
- 17-24 2s+3s+1s dance Allemande
- 25-32 1s+2s dance 1/2 R&L **while** 3s set & cross RH, 2s+3s+1s set & cross RH. 2 3 1

THE NORTHERN LIGHTS				3x32 S	
		1 3 R	2 3 1 A	$\overbrace{1\ 2} \quad 3$ RL S X_R	2x 3x 1x S X_R

Charles Doble, TAC Silver

3C/3C longwise set.

LINKS WITH ST PETERSBURG (J8x32) 3C (4C set) Malcolm Brown RSCDS Bk 46

- 1- 8 1s & 2s Set+Link ending 2s facing 1s NHJ, 2s & 1s Set+Link with partners to opposite sides. (2)(1)3
- 9-16 1s followed by 2s dance down for 3 bars & change places with Lady dancing under Mans arm, 2s+1s dance up to 1st & 2nd places
- 17-24 2M+1M turn LH as 2L+1L turn RH, 1M+3M turn RH as 1L+3L turn LH & 1s end facing 1st corners
- 25-32 1s dance 'Hello-Goodbye' setting & petronella turn to 2nd place own sides

LINKS WITH ST PETERSBURG				8x32 J	
1 2 S & LINK		2x 1x 2 1 			S S S T_◇

Malcolm Brown, 2009, RSCDS Book 46.10

3C/4C longwise set.