



The Royal Scottish Country Dance Society

Stockholm Branch

Dansprogram 19 januari 2026

Hej alla advanced dancers

Välkomna till en ny spännande vårtermin där vi skall gå igenom en hel del formationer och repetera saker som vi gjort tidigare.

Ansvariga för Advanced timmen under våren kommer att vara Susanne och Tanja.

- THE FALKIRK LASS (S8x32) 3C (4C set) RSCDS Bk 53**
- 1- 8 1s turn RH, cast 1 place, cross LH & cast round 2nd corners to 1M between 2s facing down & 1L between 3s facing up
- 9-16 All Adv+Ret (1 step), change places with opposite person RH, Adv+Ret again & 2s+3s change places RH **while** 1s turn RH to face 1st crnrs
- 17-24 1s dance Pass+Turn with 1st corners & pass RSh to face 2nd corners, dance Pass+Turn with 2nd corners & pass RSh to 2nd place own sides
- 25-32 2s+1s+3s circle 6H round & back

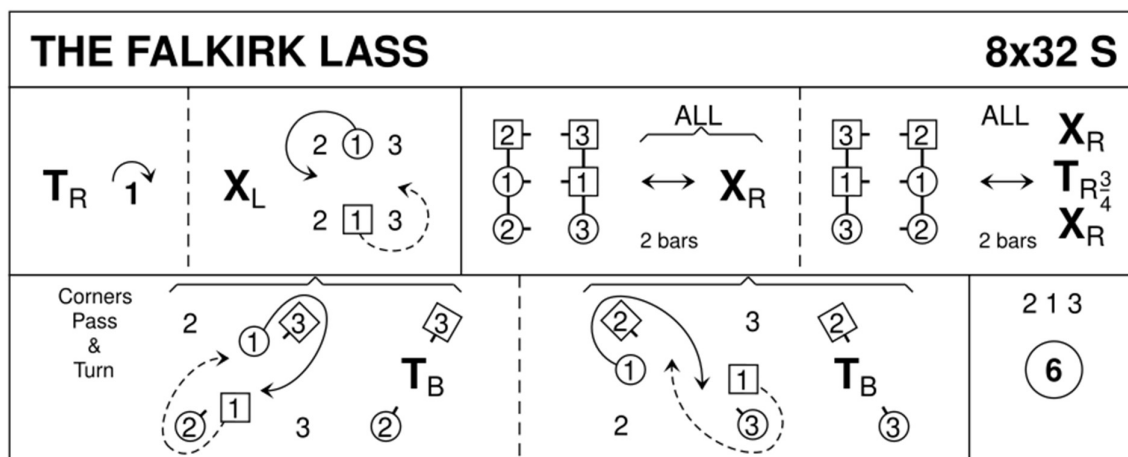

Elaine Brunken, RSCDS Book 53, Merse Collection, Moments in Time

3C/4C longwise set.

- TRIP TO TIMBER RIDGE (R8x32) 3C (4C set) RSCDS Bk 52**
- 1- 8 1s turn RH, cast (2s step up) then 1L+2s & 1M+3s dance RH across. 1s end facing 1st corners
- 9-16 1s dance Corner Pass+Turn with 1st corners, pass RSh & repeat with 2nd corners. 1s pull back RSh to end BtoB in centre facing opp sides
- 17-24 2s+1s+3s dance Double Triangles. Bars 23-24 1s petronella turn to 2nd place own sides
- 25-32 2s+1s+3s circle 6H round and back



The Royal Scottish Country Dance Society

Stockholm Branch

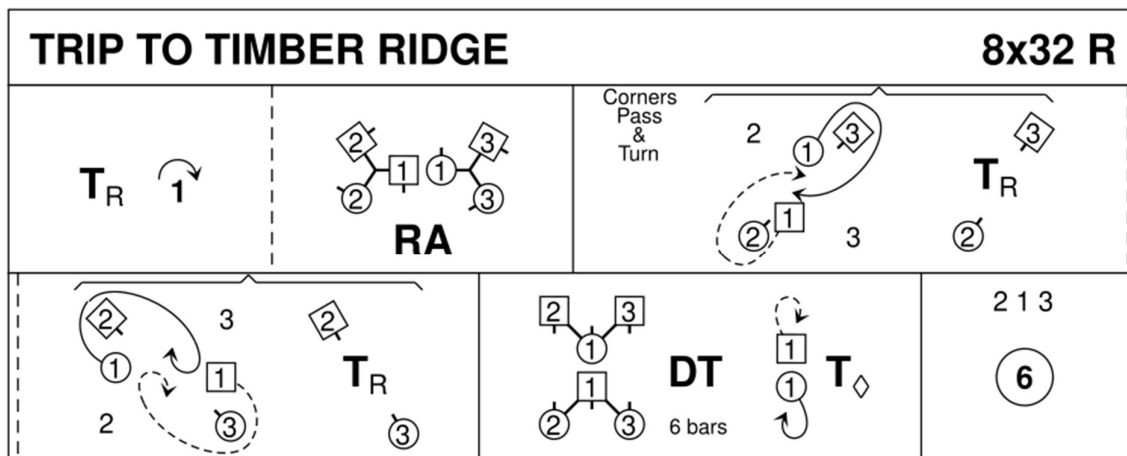

Linda Henderson, 2010, RSCDS Book 52.12

3C/4C longwise set.

TOMALENA (R5x32) 5C Set

S Gratiot+P Douglas San Francisco Coll 2

- 1- 8 1s & 3s lead down & up to 2nd/4th places BtoB facing own sides
- 9-16 All dance Double Triangles with 1s & 3s ending in middle facing up
- 17-24 1s & 3s dance up between 2s/4s & cast down 1 place, dance down between lower couple & cast up to 2nd/4th places
- 25-32 1s+4s **also** 3s+5s dance Poussette. 2 4 1 5 3

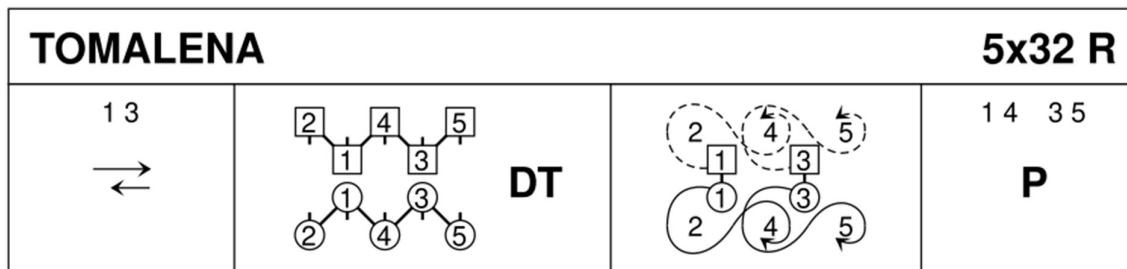

Sara Gratiot & Paul Douglas, 1984, San Francisco 2

5C/5C longwise set.