



The Royal Scottish Country Dance Society

Stockholm Branch

Dansprogram 25 november 2024

Hej alla dansare

Terminen börjar lida mot sitt slut och vi hoppas att ni kan dansa på våra sista måndagar innan jul. Anders och jag åker till Spanien i december och missar tyvärr julavslutningen. Eftersom denna kommer att ske tillsammans med nybörjarna så kommer vi de två sista gångerna innan dess ha med alla danser som finns med på avslutningsprogrammet, så att alla är bra förberedda.

Då vi inte kan vara med på avslutningen så tycker vi det skulle vara trevligt om vi kunde träffas lite och gå ut på den närbelägna puben "Kontoret" efter dansen den 25/11.

Hoppas ni tycker det är en trevlig idé!

Tidiga adventhälsningar
Susanne & Anders



THE QUICKSILVER REEL (J8x40) 3C (4C set)

Tim Harrison, 2000

- 1- 8 1s dance Figs of 8 on own sides (in & down to start)
- 9-16 3s dance Figs of 8 on own sides (in & up to start)
- 17-24 2s dance Figs of 8 on own sides (out & up to start)
- 25-32 1s+2s+3s dance mirror reels of 3 on own sides (1s in & down to start)
- 33-40 1s cross RH & cast 1 place, 1s dance 1/2 Fig of 8 up round 2s. End 2 1 3

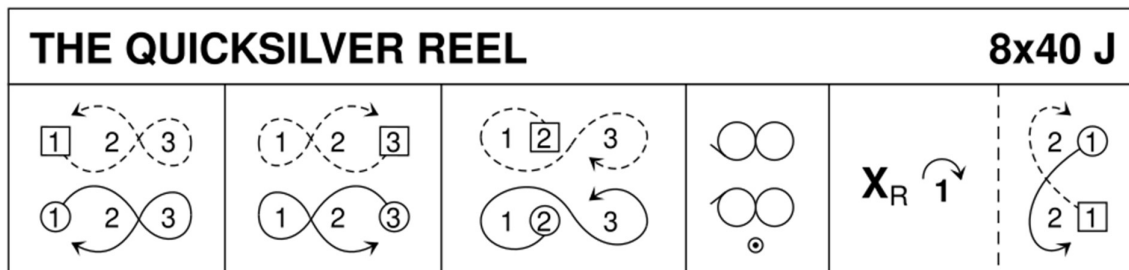

Tim Harrison, 2000, www.timdoodle.com/scd/QuicksilverReel.html

3C/4C longwise set.



The Royal Scottish Country Dance Society

Stockholm Branch

THE HIGHLAND RAMBLER (R8x40) 3C (4C set) Roy Goldring Leeds Silver Jubilee

- 1- 8 1s dance in & cast to 2nd place, dance RH across with 3s
- 9-16 2s+1s dance LH across, 1L followed by partner cast up round 2L & dance down middle to 1L between 3s & 1M between 2s
- 17-24 1s+2s+3s dance down the middle & back
- 25-32 1M followed by partner dance up, cast down round 2L to 2nd places on own side & turn RH
- 33-40 2s+1s+3s circle 6H round & back

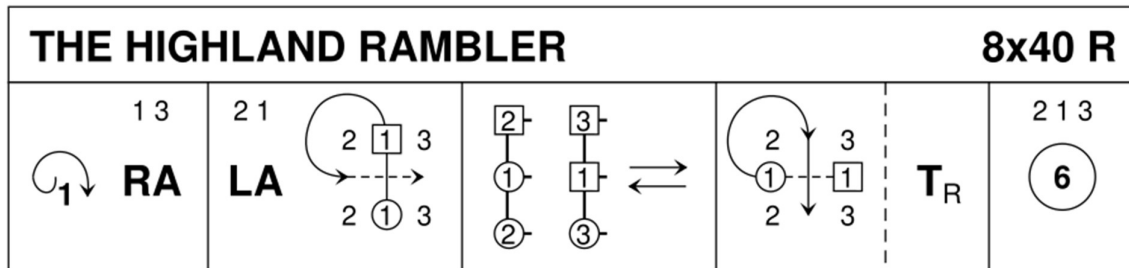

Roy Goldring, 1985, Leeds Silver Jubilee, RSCDS Thirty Popular Dances Vol 2

3C/4C longwise set.

LADY GLASGOW (S8x32) 3C (4C set)

MMM 1

- 1- 8 1s+2s+3s set cross RH, set & 1/2 turn RH into Promenade hold
- 9-16 1s+2s+3s Promenade
- 17-24 1s set & cast to 2nd place, 1s dance DoSiDo
- 25-32 2s+1s+3s circle 6H round & back

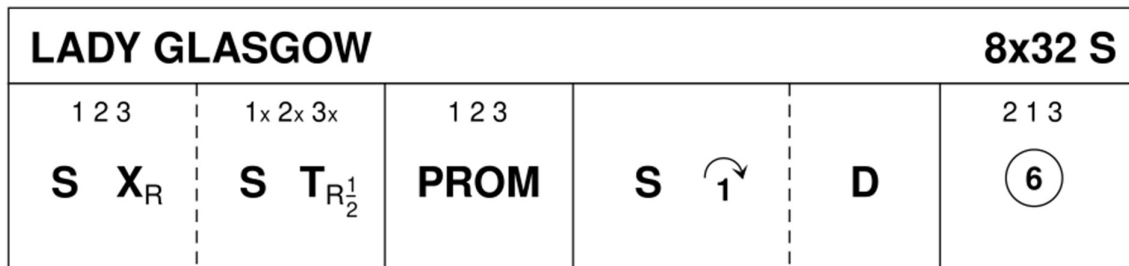

RSCDS MMM (45)

3C/4C longwise set.



The Royal Scottish Country Dance Society

Stockholm Branch

- THE ABC JIG (J8x32) 3C (4C set) Brenda Burnell Silver Thistle Coll**
- 1- 8 1M+3L set advancing to join RH with each other & LH with partners in diagonal line, Bal-in-Line, 1s+2L also 3s+2M dance LH across
- 9-16 1L+3M set advancing to join LH with each other & RH with partners, Bal-in-Line, 1s+2M also 3s+2L dance RH across
- 17-24 1L followed by partner casts behind 2L, cross, casts down behind 3M & dances up the middle with partner
- 25-32 1s dancing between 2s turn them with nearer hand, dance in & down between 3s & turn them with nearer hand (1.1/2 times 2nd time through)

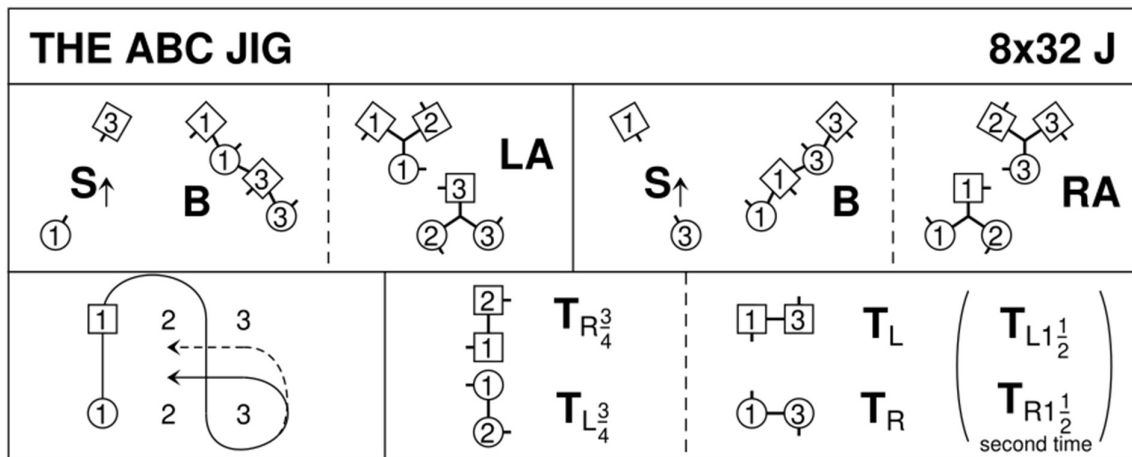

Brenda Burnell, Silver Thistle Collection

3C/4C longwise set.

- THE DUNEDIN FESTIVAL DANCE (R32) Round the Room Derek Haynes Dunedin 4**
- 3 Couple Circles
- 1- 8 All circle 6H round & back
- 9-16 All dance DoSiDo with partner & turn partner RH
- 17-24 All dance RH across, Lady (whose hand is underneath) dances out under arch into prom hold with next partner followed by next Lady etc
- 25-32 All Promenade with new partners anywhere round the room & meet with another 2 couples to start again

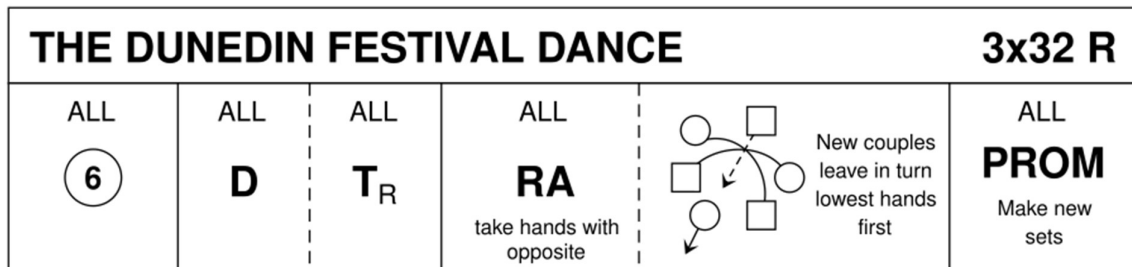

Derek Haynes, 1991, A Guide to Scottish Country Dancing, Dunedin Dances 4

3C/3C triangular set.



The Royal Scottish Country Dance Society

Stockholm Branch

THE LEA RIG (S8x32) 2C (4C set)

RSCDS Bk 21

- 1-16 1s dance full Petronella figure back to place **while** 2s step up bars 1-2, set bars 3-4, then follow 1s. 2s petronella turn to 2nd place on bars 15-16
- 17-24 1s lead down centre of set & back to top
- 25-32 1s+2s dance RH across once round & 1/2 Diamond Poussette to change places

THE LEA RIG				8x32 S
1 2 2C start on bar 3			1 2 RA	1 2 P

RSCDS Book 21.5

2C/4C longwise set.

ALLEMANDE JOY (J8x32) 3C (4C set)

Martha Morrison Veranth 1997

- 1 - 8 1s cross RH and cast off (2s move up), dance 1/2 fig of 8 round 2s (2, 1, 3)
- 9 -16 1s cross RH, 2M+3L change place RH, 2L+3M change place RH, all half turn RH to face up ready for Allemande
- 17-24 3s+1s+2s Allemande
- 25-32 2s+1s+3s circle 6H round & back. End 2, 1, 3

ALLEMANDE JOY				8x32 J	
				3 1 2 A	2 1 3

Martha Morrison Veranth,, 1997

3C/4C longwise set.



The Royal Scottish Country Dance Society

Stockholm Branch

THE SILVER TASSIE (S8x32) 3C (4C set) John Drewry Bon Accord Bk
 1- 8 1s+2s+3s cross RH & set, cross back RH & set
 9-16 1s & 3s dance double Fig of 8 round 2s (3s casting)
 17-24 1s followed by 2s+3s dance down, 1s followed by 2s+3s (who part to let 1s thru)
 dance back to top
 25-32 1s+2s dance the Rondel

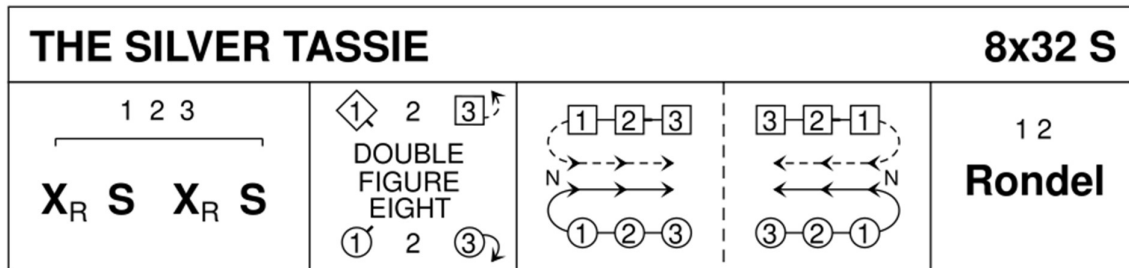

John Drewry, 1966, RSCDS Leaflet 1

3C/4C longwise set.

EXTRA

PUFFIN'S REEL (R8x32) 3C (4C set) Terry Harvey, Delaware Valley RSCDS
 1- 8 1s+2s set & dance 1/2 RH across; 1s+3s set & dance 1/2 LH across. (2) (3) 1
 9-16 1s lead up to top, cross & cast round 2s, meet, dance down between 3s & cast up
 to 2nd place opposite sides (3s step down 15-16). (2) (1) (3)
 17-24 2s+1s+3s Set+Link for 3 couples twice. 3 1 2
 25-32 3s+1s+2s circle 6H round & back. End 3 1 2

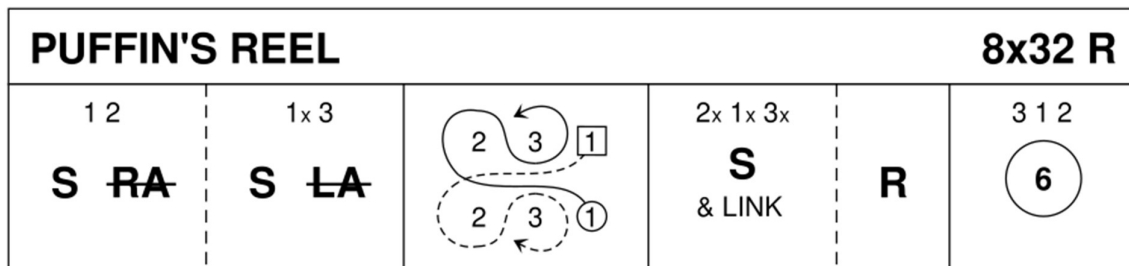

Terry Harvey, Delaware Valley RSCDS

3C/4C longwise set.